

# JAZZ



Jazz is a sporty and chic garment, made with the soft and light Scotland a tweed 100% Lana Rws.



**Yarn:** SCOTLAND col. 1358 Beige.

**Needles:** n. 3 e 3,5

**Weight:** 200 g/ 7 oz., 4 balls.

**Sizes:** S, M, L

**Stitches Used:** 2x2 Rib, Tubular, Stockinette Stitch, Honeycomb Stitch.

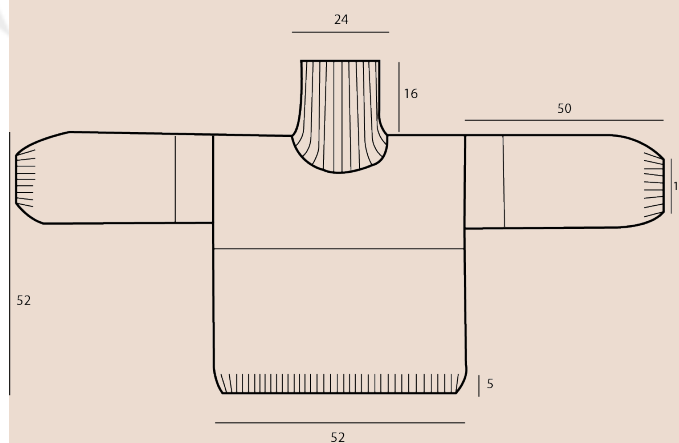

**Gauge:** 10 cm x 10 cm (4 in. x 4 in.) = 27 stitches and 31 rows.

**Explanation Honeycomb Stitch:**

Work over a multiple of 8 stitches.

**1st- 3rd- 11th- 13th Rows:** purl.

**2nd- 12th Rows:** knit.

**4th- 6th- 8th- 10th Rows:** \*purl3, sl st2 purlwise (= move 2 stitches from the left needle to the right needle without purling them), purl3\*, repeat from \*to\*.

# JAZZ



**5th- 7th- 9th Rows:** \*knit3, sl st2 purlwise, knit3\*.  
**14th- 16th- 18th- 20th Rows:** \*sl st1 purlwise, purl6, sl st1 purlwise\*.  
**15th- 17th- 19th Rows:** \*sl st1 purlwise, knit6, sl st1 purlwise\*  
21st Rows: repeat from the first row.

## KNITTING THE BACK

Using needle n. 3 and SCOTLAND yarn, cast on 126 (130, 134) stitches and work in **Tubular** for 2 rows, then in **2x2 Rib** for 16 (16, 18) rows. Continue in **Stockinette Stitch** with needles n. 3.5, increasing 4 stitches while making the first row, and perform 52 rows. Then work in **Honeycomb Stitch** and continue up to a total height of 52 (54, 56) cm/20,50 (21,30; 22) in. Work 2 rows in **Stockinette Stitch**, then bind off all stitches.

## KNITTING THE FRONT

Using needle n. 3 and SCOTLAND yarn, cast on 126 (130, 134) stitches and work in **Tubular** for 2 rows, then in **2x2 Rib** for 16 (16, 18) rows.

Continue in **Stockinette Stitch** with needles n. 3.5, increasing 4 stitches while making the first row, and perform 52 rows.

Then work in **Honeycomb Stitch** and continue with this working.

At a total height of 47 (48, 49) cm/18,50 (18,90; 19,30) in., for the neckline, bind off the 22 (24, 26) central stitches and continue binding off, at neckline' sides, every 2 rows, 3 stitches twice and 2 stitches 4 times.

At a total height of 52 (54, 56) cm/20,50 (21,30; 22) in., work 2 rows in **Stockinette Stitch**, then bind off the 40 (41, 42) stitches of each shoulder.





# JAZZ



## SLEEVES

Using needle n. 3 and SCOTLAND yarn, cast on 72 (74, 78) stitches and work **Tubular** for 2 rows, then in **2x2 Rib** for 12 (12, 14) rows.

Continue in **Stockinette Stitch** with needles n. 3.5. At a total height of 6 (6.5; 7) cm/2,40 (2,60; 2,80) in., start increasing at sides 2 stitches every 6 rows 6 times, then 1 stitch every 8 rows 6 times.

We will get 108 (112, 116) stitches in total.

Once you have made 100 (104, 108) rows in **Stockinette Stitch**, start working in **Honeycomb Stitch** and continue up to a total height of 50 (52, 54) cm/19,70 (20,50; 21,30) in.

Make 2 rows in **Stockinette Stitch**, then bind off all stitches.

Make the second sleeve as the first one.

## FINISHING

Sew sides and one shoulder. For the collar, using needle n. 3.5, pick up 118 (108, 110) stitches in total, along the entire neckline (front + back), and work in **2x2 Rib** for 50 (52, 54) rows, then bind off all stitches.

Sew the other shoulder and underarms, apply the sleeves.

